

Facette® Shades

HunterDouglas® Facette® Shades offer a choice when it comes to light and privacy control. A combination of stylish, soft fabric in a practical design.

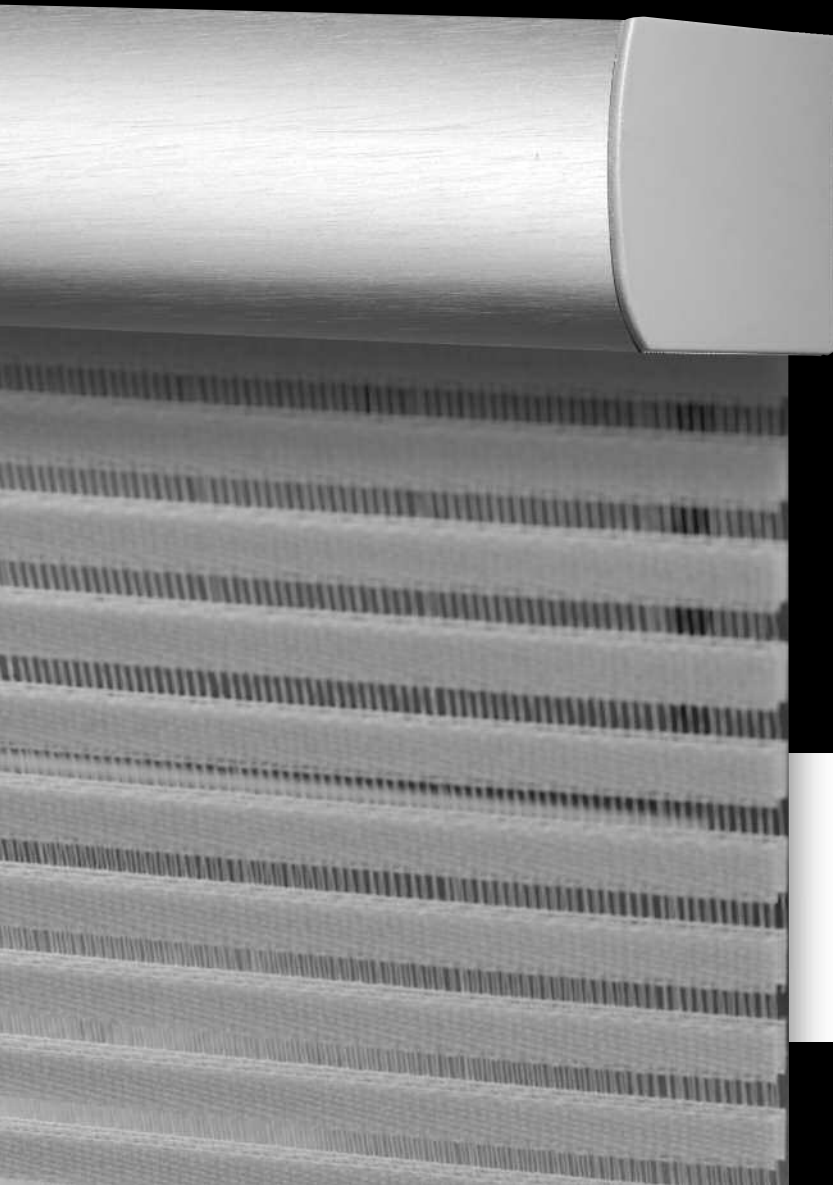

HunterDouglas

WINDOW COVERINGS



Facette® Shades

Soft fabrics for subtle light control

DESIGN

HunterDouglas® Facette® Shades offer a unique combination of stylish, soft fabric and optimal light and privacy control. Highly elegant and practical.

HunterDouglas® Facette® Shades provide increased comfort and safety. Facette® Shades are made with 100% TREVIRA CS high quality yarns, fire retardend according to M1 and B1. The Shades combine the ultimate in style and functionality.

FUNCTIONALITY & COMFORT

The innovative fabric features alternating, moveable layers of translucent and opaque parallel segments, to control daylight any time of the day. The stylish soft fabric creates an inviting ambiance in any room, transforming interiors with the glow of warm light.

DESIGN, FUNCTIONALITY & DURABILITY

The Facette® Shades hardware systems have been designed to offer easy mounting. The Facette® Shades can be installed in recess, on face of the window or on the wall.



LIGHT & ENERGY

HunterDouglas® Facette® Shades are designed to improve indoor environmental quality and conserve energy. These systems help create built environments that are comfortable, healthy, productive, and sustainable. Our engineering and production processes minimize embodied environmental impact while meeting the highest standards for commercial, hospitality, industrial, institutional, and commercial applications. In order to obtain the optimal shading performance for a building and its occupants we developed compute simulation and calculation tools. Our project support team can analyze, visualize and optimize Window Covering Solutions with the HunterDouglas® Light and Energy Tool.

CONTENT

Page

Facette® Shades

2 - 3

Indoor Environmental Quality
& Productivity

4

Light & Energy Tool

5

Impressions

6 - 7

Innovative Products Make Innovative Projects



HunterDouglas

Facette® Shades

CASSETTE OR COVER PROFILE:

Extruded aluminium profile with plastic end caps

Dimensions Cassette or Cover Profile

81 x 68 mm (W x H)

Colour

natural anodized aluminium or powder coated

Tube description

double taped extruded aluminium profile

Tube dimensions

Ø 35 mm (1.4 mm wall thickness)

Tube colour

mill finish or powder coated white

BOTTOM RAIL:

Uncovered extruded aluminium profile with zinc plated steel bottom weight and plastic end caps

Dimensions Bottom rail

26 x 14 mm (W x H)

Colour

natural anodized aluminium or powder coated

FABRIC DESCRIPTION

Patented double layer flat fabric of Trevira CS high quality yarns with alternating open and closed stripes in 3 widths:

- small 4 mm pitch
- medium 7 mm pitch
- large 14 mm pitch

Facette® Shades are suitable for humid environment and are antistatic, which repels dirt from the fabric for a longer time. The fabric is easy to clean with a wet tissue or can be cleaned ultrasonic.

Fabric properties

Fire retardant according to M1 and B1. Excellent in reducing harmful UV radiation and Antistatic. Suitable for wet areas.

MANUAL CONTROL

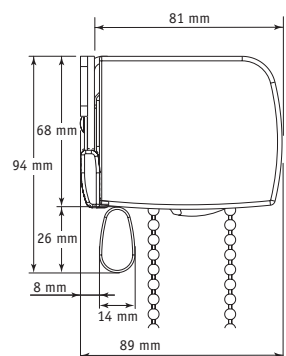
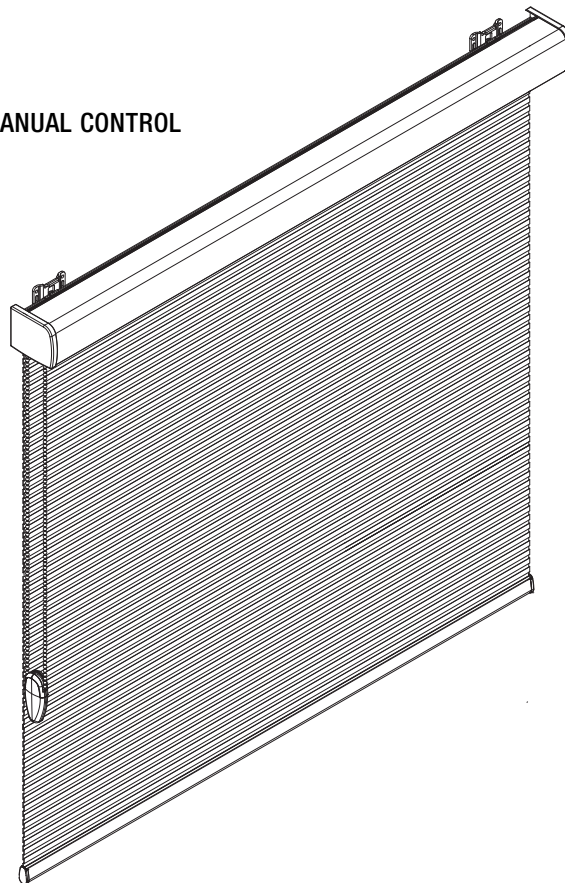

Facette® Shade

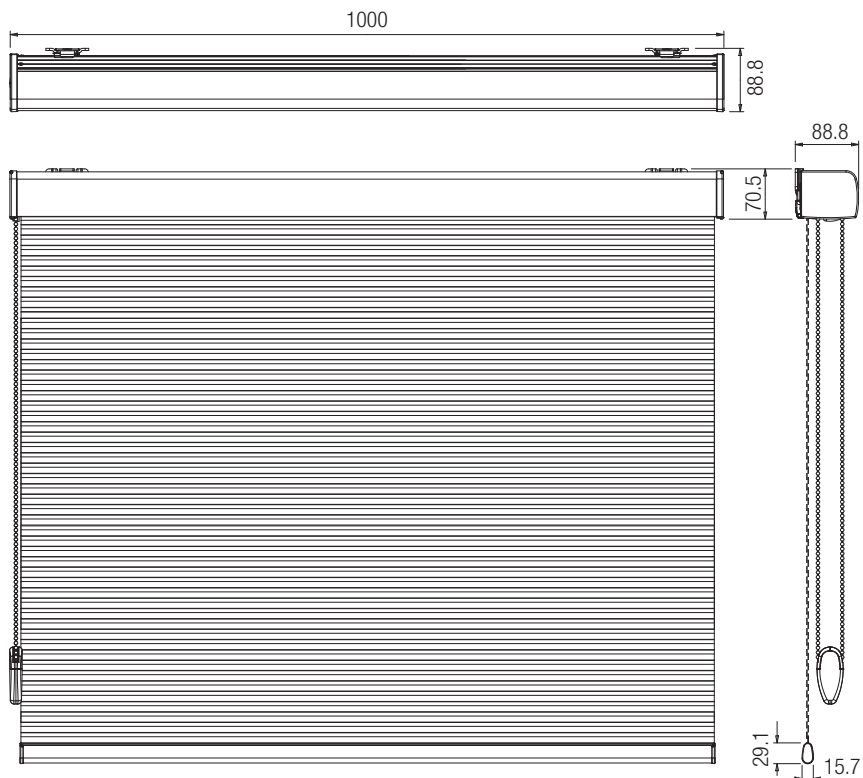

Facette® Shade

Facette® Shades

COLOR RANGE

A special project collection with contemporary and diverse colors are available. In addition to this main color range, the Facette® project collection will be complemented regularly by one or more additional trend colors.

COLOR-COORDINATION

The fittings (cover profiles, bottom rails, end caps) on Hunter Douglas Facette® Shades are color coordinated to the choice of fabric. Alternatively, Facette® Shades can be personalized with white or anodized fittings.

THE PRODUCT DIMENSIONS:

| Min. Width | Max. Width | Min. Height | Max. Height | Max. Surface |
|------------|------------|-------------|-------------|--------------------|
| 350 mm | 2,500 mm | 300 mm | 2,500 | 4.6 m ² |

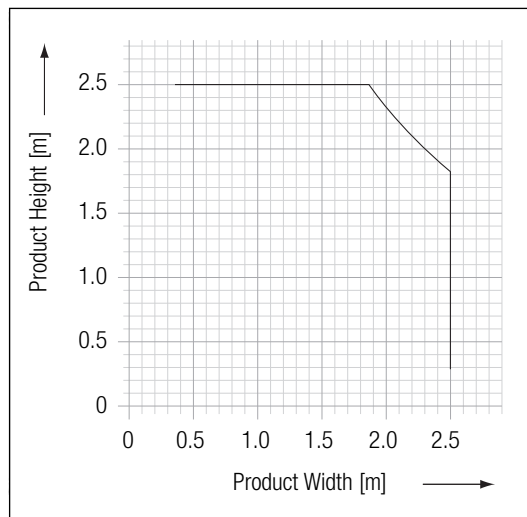

DISTANCE BETWEEN BOTTOM RAIL AND WINDOW SILL

Facette® fabric is attached to the roller tube and bottom rail, which makes it possible to open and close the segments of the fabric. As a result, the distance between the bottom rail and the window sill has the following variance.

| | Distance bottom Rail to Windows Sill | |
|----------------|--------------------------------------|------------------|
| | Minimum Distance | Maximum Distance |
| Facette Small | 3 mm | 11 mm |
| Facette Medium | 3 mm | 17 mm |
| Facette Large | 3 mm | 31 mm |

OPERATION

The fabric can be pulled up, lowered, opened and closed by a chain. The fabric is pulled up in an entirely closed or opened position. The fabric can be opened or closed only when it has been fully lowered.

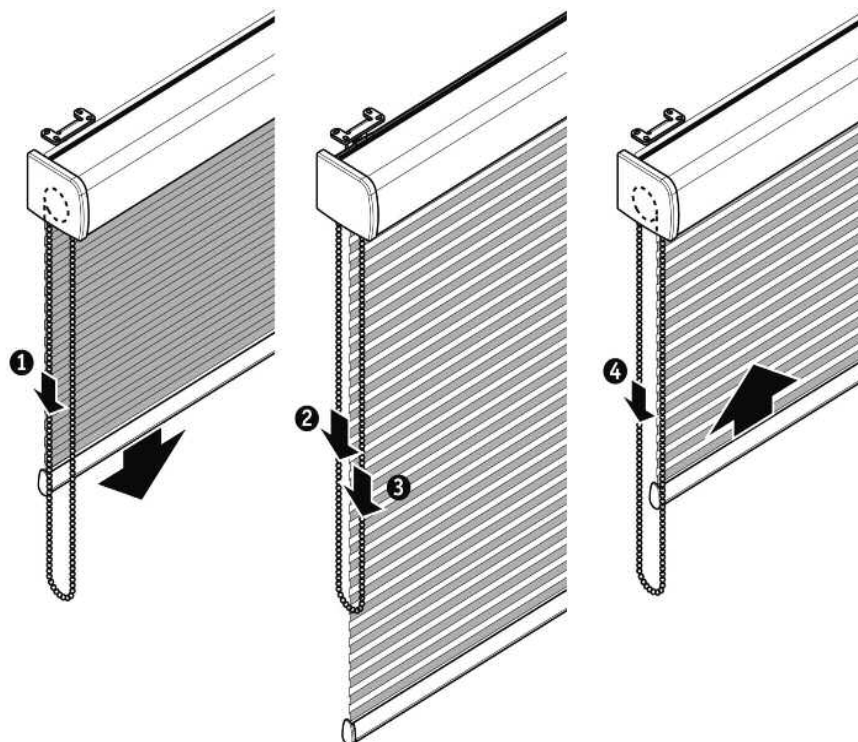

Indoor Environmental Quality & Productivity

PRODUCTIVITY

Energy saving strategies and natural resources like daylight, can create a comfortable and productive environment for occupants. Smart, sustainable design that provides good indoor environmental quality is a proven and profitable investment.

Seemingly small increases of as little as 1% in productivity could result in a much higher payback than the reduced cost of energy.

COMFORT

Comfort can be described as 'the state of mind that expresses satisfaction with the surrounding environment'

Indoor environmental quality has essentially four dimensions:

1. Thermal comfort;
2. Visual comfort;
3. Acoustic comfort;
4. Indoor air quality.

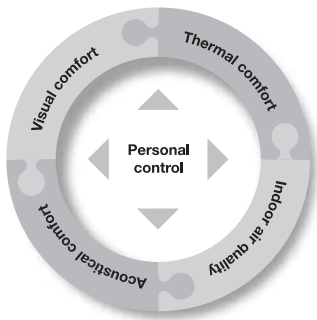

It is an accepted fact that people prefer to experience daylight through visual contact with the outside world. This is therefore, generally recognized as an important factor in influencing people's positive emotional state.

Situations that cause visual discomfort can frequently arise. The light, glare or reflection levels are just too bright and contrasts too large for optimal working conditions.

Workspaces which are comfortable, naturally lit and allow occupants to connect with outdoor space can improve productivity and reduce absenteeism. Research on the relationship between day lighting and productivity shows that the use of daylight without glare resulted in productivity gains in the order of 4%. To fully optimise the benefits of daylight, control systems can be integrated in the sun control solution.

SUSTAINABILITY & INDOOR ENVIRONMENTAL QUALITY

The environmental footprint of a building includes such factors as the use of energy, water, materials and resources. Hunter Douglas Sun Control systems and Window Covering products can play an excellent role in reducing the environmental footprint, whilst at the same time enhancing the thermal and visual dimensions of indoor environmental quality.



Energy and Light Tool

The function of Window Coverings is to provide visual comfort and heat control. The primary function of interior window coverings is to reduce glare levels and diffusing daylight. The primary function of External Window Coverings is heat control.

THERMAL COMFORT

External Window Coverings will prevent excessive solar heat gain and reduce the need for cooling in the summer. Moreover, it will also reduce - if not eliminate - the high capacity of cooling equipment needed, resulting in a reduction in the initial investment cost.

In colder climates, External Window Coverings will enable the use of solar energy to help heat the building in winter. This is often overlooked when solar control glass is selected for heat control.

Thermal comfort at a minimal environmental impact calls for a careful matching of glazing, Sun Control and HVAC equipment.

Hunter Douglas Energy Tool helps finding an optimum solution by quantifying the effects of various External Window Coverings. The pay-off will be reduced energy costs and often reduced investment cost, and on top of that: reduced greenhouse gas emission during the operation phase of the building.

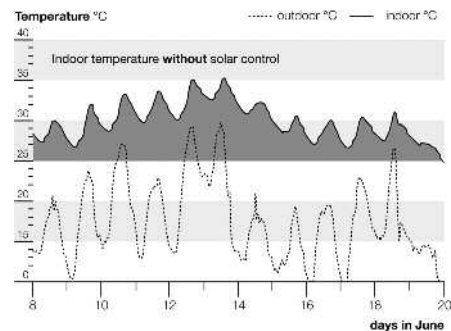

Indoor and outdoor temperature without External Window Covering

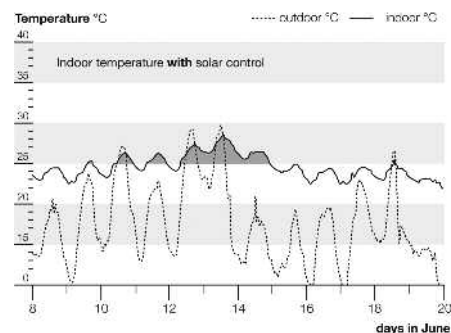

Indoor and outdoor temperature with External Window Covering

VISUAL COMFORT

Interior window coverings enable the use of free renewable daylight to the maximum extent, so significantly reducing the need for artificial lighting and avoiding the associated cooling loads.

The accepted factor in creating visual comfort states that the contrast within the field of view should not exceed a factor of 10. The contrast between the central visual task and its direct surroundings should not exceed a factor of 3.

When designing an office space, questions often arise around what measures should be considered to guarantee the right level of visual comfort?

Hunter Douglas Light Tool makes the assessment of visual comfort tangible by calculating luminance levels for a model office with and without window coverings. The amount and type of glass, the orientation of the facade, the geographical location, weather, season and time of day are all taken into account before recommendations are made.

The Light Tool helps client's assess which window covering provides the aesthetic and performance levels needed to create visual comfort for their particular project.

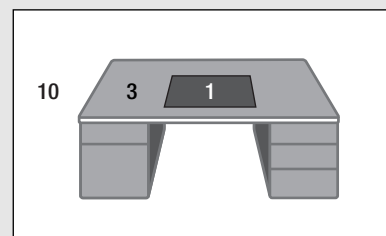
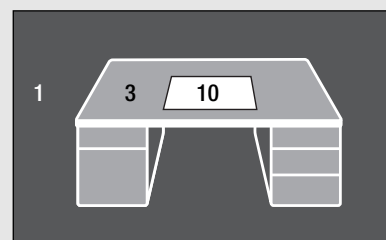

Contrast factor 1:3:10

Light Tool calculations are based on Radiance (Lawrence Berkeley Laboratories). The scene model consists of approximately 20,000 polygons. Colours and reflection values were measured in an actual model office.

Impressions

Cassette and Bottom rail, manual operation



Dimensions fabric:

- Large, 14 mm pitch (picture left side)
- Medium, 7 mm pitch (picture right side)



Impressions

Daylight and Privacy control:

- Fabric segments are closed
- Fabric segments are half open
- Fabric segments are open

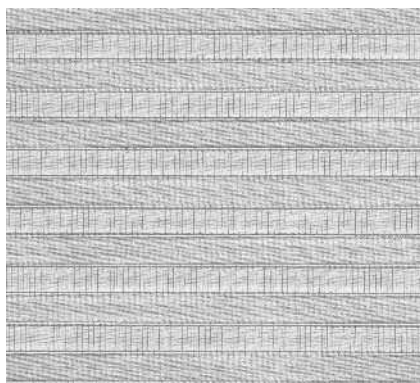

Closed segments

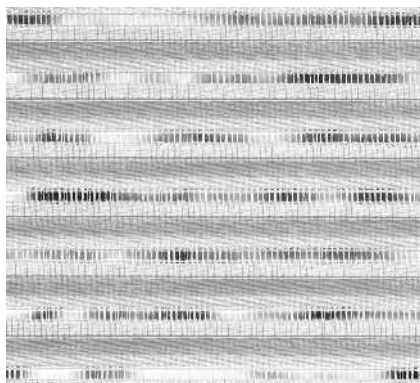

Half open segments

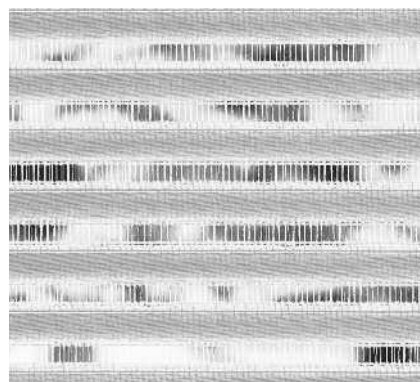

Open segments

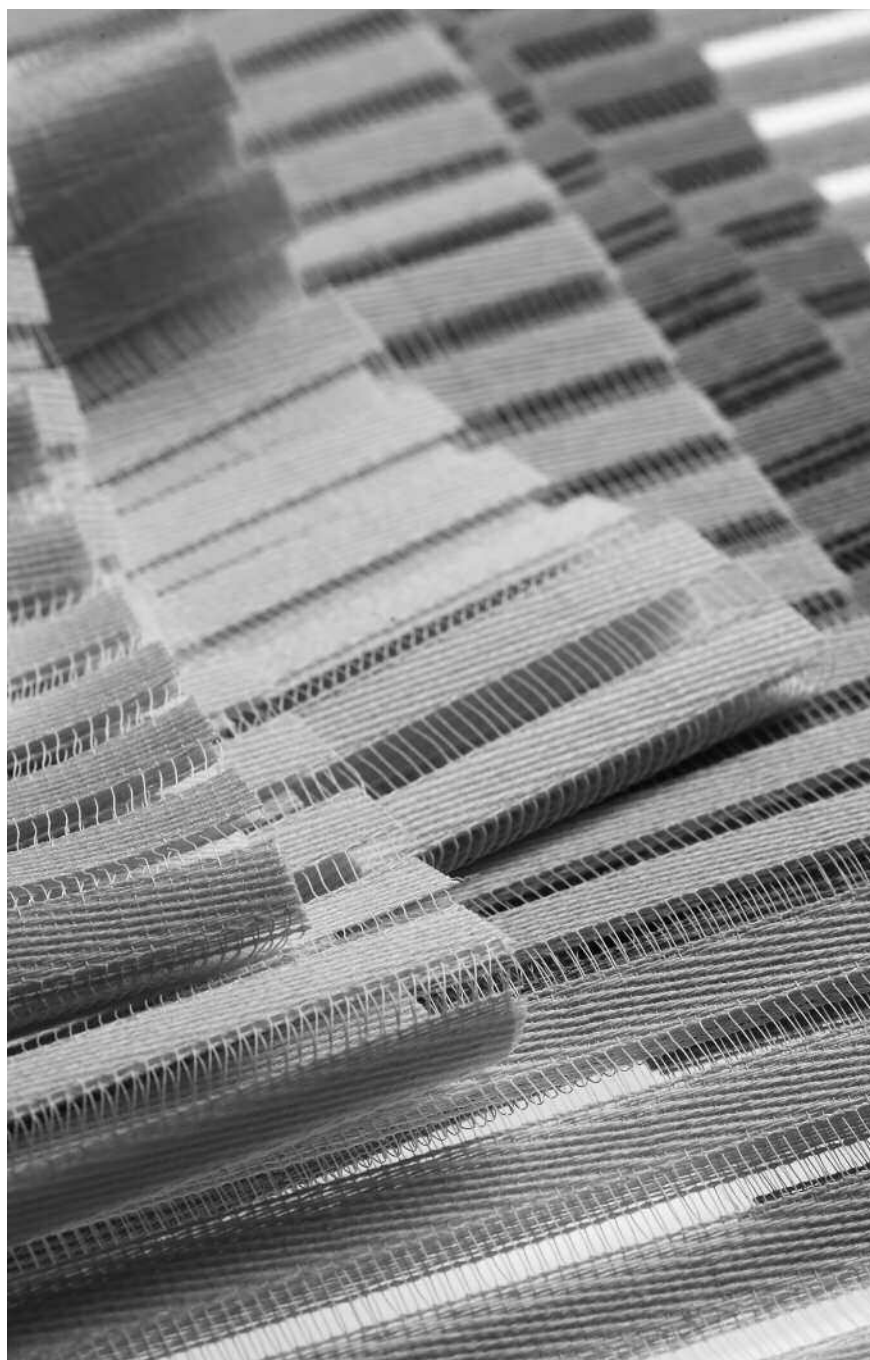



HUNTER DOUGLAS ARCHITECTURAL PRODUCTS

Over 40 years, Hunter Douglas has been dedicated to innovation. As the field of Sun Control grows, we pride ourselves on leading the way as pioneers in the area.

We're working alongside architects and designers throughout the globe, developing new, innovative methods of managing heat, light and energy. We've committed ourselves to crafting products that meet the highest standards of materials, construction and performance because we believe that you need the right tools to create projects that inspire.

Innovative Products Make Innovative Projects



Promoting sustainable
forest management
www.pefc.org

© Registered trademark - a HunterDouglas® product Pats. & Pats. Pend. - Technical data subject to change without notice.
© Copyright Hunter Douglas 2009. No rights can be derived from copy, text pertaining to illustrations or samples. Subject to changes in materials, parts, compositions, designs, versions, colours etc., even without notice. **MX915W00**



ARCHITECTURAL SERVICES

We support our business partners with a wide range of technical consulting and support services for architects, developers and installers. We assist architects and developers with recommendations regarding materials, shapes and dimensions, colours and finishes. We also help creating design proposals, visualisations and mounting drawings. Our services to installers range from providing detailed installation drawings and instructions to training installers and advising on the building site.

HunterDouglas

WINDOW COVERINGS



Learn More

- Contact our Sales Office
- www.hunterdouglascontract.com

Roller Blinds



Venetian Blinds

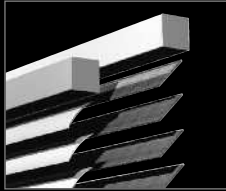

Plissé & Duette® Shades



Vertical Venetian Blinds

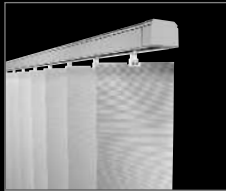

Facette® & Silhouette®

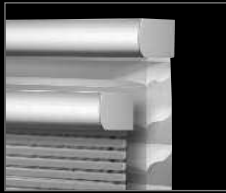

External Venetian Blinds



External Roller Blinds



- Austria
- Belgium
- Bulgaria
- Croatia / Slovenia
- Czechia
- Denmark
- France
- Germany
- Greece
- Hungary
- Ireland
- Italy
- Kazakhstan
- the Netherlands
- Norway
- Poland
- Portugal
- Romania
- Russia
- Serbia
- Slovakia
- Spain
- Sweden
- Switzerland
- Turkey
- Ukraine
- United Kingdom
- Africa
- Middle East

- Asia
- Australia
- Latin America
- North America

HUNTER DOUGLAS EUROPE B.V.
2, Piekstraat
P.O. Box 5072 - 3008 AB Rotterdam
Tel. +31 (0)10 - 4869911
Fax +31 (0)10 - 4847910
www.hunterdouglascontract.com

HunterDouglas

WINDOW COVERINGS | CEILINGS | SUN CONTROL | FAÇADES