

# FABER 1800 OL

## BLACKOUT BLIND SYSTEMS FOR ROOFLIGHT WINDOWS

Uniclass	L422
Cl/SfB	(76.7)



Faber 1800 OL is an efficient and flexible blackout blind system for internal use specifically designed for applications where a horizontal or slanted blind is required e.g. rooflight windows, glazing in pitched roofs, atriums or similar. The system is especially suitable for concealed installations in a recess or above a ceiling when provision is made for this at the design stage of a project. The advantage of a concealed installation is that the blind hardware will not be visible when the blind is operated. The dimension and configuration of the individual components such as the blind box, side channels and bottom channels

are adapted to the type of installation and size of blind installed.

Several control options are offered with the Faber 1800 OL system. Manual control using a rod operated gearbox is a simple and low cost solution for smaller blind sizes and installations where the blinds are accessible. Electric operation is available for high level or inaccessible installations and large areas of glazing, or where the blinds need to be grouped and centrally controlled. An FTS system is also available with Faber 1800 OL Blackout Blinds, using a motor at each end of the blind. This is

particularly suitable for large skylight windows and areas of high level glazing in atriums where it is important the fabric is held under tension at all times.

There is a choice of flame retardant blackout fabrics and an important feature of the system is that each fabric has Ø3 mm horizontal steel rods welded onto the back at 600 mm intervals. This ensures that the fabric is fully and evenly stretched throughout its width and remains in the side channels even when subjected to draughts in the room.

### Applications

- Faber 1800 OL blackout blinds are used for internal applications where an efficient, individually adapted blackout system is required for horizontal glazing areas or sloping windows.
- Atriums and other high level areas of glazing.
- Skylight windows in conference rooms, meeting rooms and training rooms.
- Rooflight windows where total light exclusion is required.

## Features

- ① Steel head box housing the roller assembly, in powder coated paint finish to RAL 9016 (white) or RAL 9004 (black). The universal head box is suitable for face, ceiling and recess fixing and is available in 2 standard sizes: 110 x 110 mm and 150 x 150 mm. For special projects with sufficient lead time the head box shape and dimensions can be purpose made to suit the requirements of the individual project.
- ② Galvanised steel roller tubes in either Ø42 or Ø57mm with an expander mounted in an end bearing to reduce the possibility of tube deflection. A spring return mechanism is mounted in the tube to keep the blind under constant tension to avoid any sagging of the fabric.
- ③ A range of galvanised steel draw tubes in either Ø40, 50 or 70 mm. The draw tube is fitted at the opposite end to the roller tube and is supplied complete with expander mounted in an end bearing to reduce the possibility of tube deflection. The motor or gear box for controlling the blind is installed in the draw tube.
- ④ A steel support section 15 x 30mm in powder coated finish RAL 9016 (white) or RAL 9004 (black) is fitted on blinds exceeding 1300mm width to give additional support to the fabric. The support section can be installed in line with existing glazing bars of the window frame in order to conceal its appearance.
- ⑤ Range of universal galvanised steel brackets with various projections to suit all blind sizes and suitable for fixing to vertical or horizontal surfaces.
- ⑥ Choice of manual rod operation or automated electric control for high level applications.
- ⑦ Blinds operated manually by means of a crank handle rod connected to a speed reducing gearbox mounted in the draw tube. A detachable type rod with collapsible handle is supplied as standard. Rods are available in different sizes ranging from 850 mm up to 1950 mm in length to suit each individual application. Each gearbox can operate blinds up to an area of 4m<sup>2</sup>.
- ⑧ Electric operation by means of a 240V tubular motor fitted into the draw tube. The motor can be located in either the left or right hand side of the tube to suit the electrical installation of the building. Several blinds can be coupled by means of an intermediate bearing and a square shaft for simultaneous operation, and each motor can operate blinds up to a maximum area of 27 m<sup>2</sup>. Standard operation is by manual push button switches but a number of control options are available including fully automated electronic systems and those linked to building management programs.
- ⑨ For FTS blinds two motors are used, one fitted in the draw tube and the other fitted in the roller tube. The motors are fitted with a built-in brake and can be mounted on either the right or left hand side of the blind but must be installed on the same side of the blind.
- ⑩ Extruded aluminium channels in powder coated paint finish to RAL 9016 (white) or RAL 9004 (black). The channels are supplied with a nylon brush light seal to ensure total light exclusion. There is a choice of 60 x 16 mm and 80 x 16 mm side channels for face and recess fixing and in addition 80 mm angle channels are available for recess mounting and for blinds exceeding 2500 mm width. With coupled blinds a special double channel 150 x 19 mm is used to prevent any ingress of light.
- ⑪ Extruded aluminium bottom bar 45 x 9 mm in powder coated paint finish to RAL 9016 (white) or RAL 9004 (black). The bottom bar includes a felt seal for effective light exclusion and plastic end plugs to seal each end and hold the bottom bar securely in the side channels.
- ⑫ A 25mm strong, durable draw tape is attached to the bottom bar and connected to the draw tube. The tape is drawn through the side channels and directly over the draw tube so that it is concealed from view.
- ⑬ For rod operation an adjustable stop action is fitted to the bottom bar to prevent the blind from being over-wound and reducing any possibility of it being pulled out of the side channels.
- ⑭ Horizontal, thin steel rods (Ø5 mm) are welded into the fabric at 600 mm intervals to keep the fabric taut across its width and to hold it firmly in the side channels thereby counteracting any traction from the weight of the fabric or movement caused by draughts.
- ⑮ There is a comprehensive range of flame retardant blackout fabrics suitable for use with this system, or dim-out fabrics for applications where total light exclusion is not required.

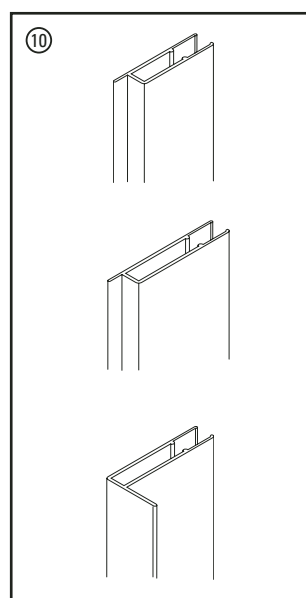
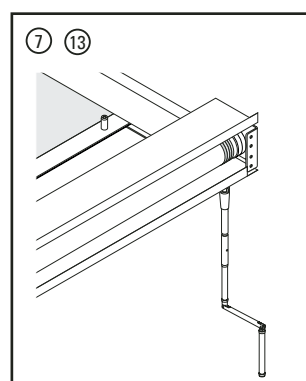
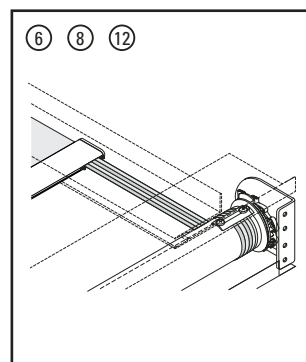
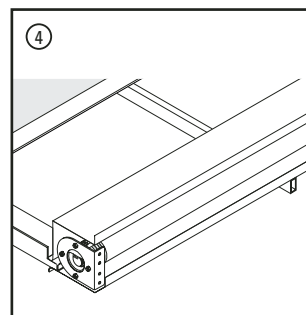

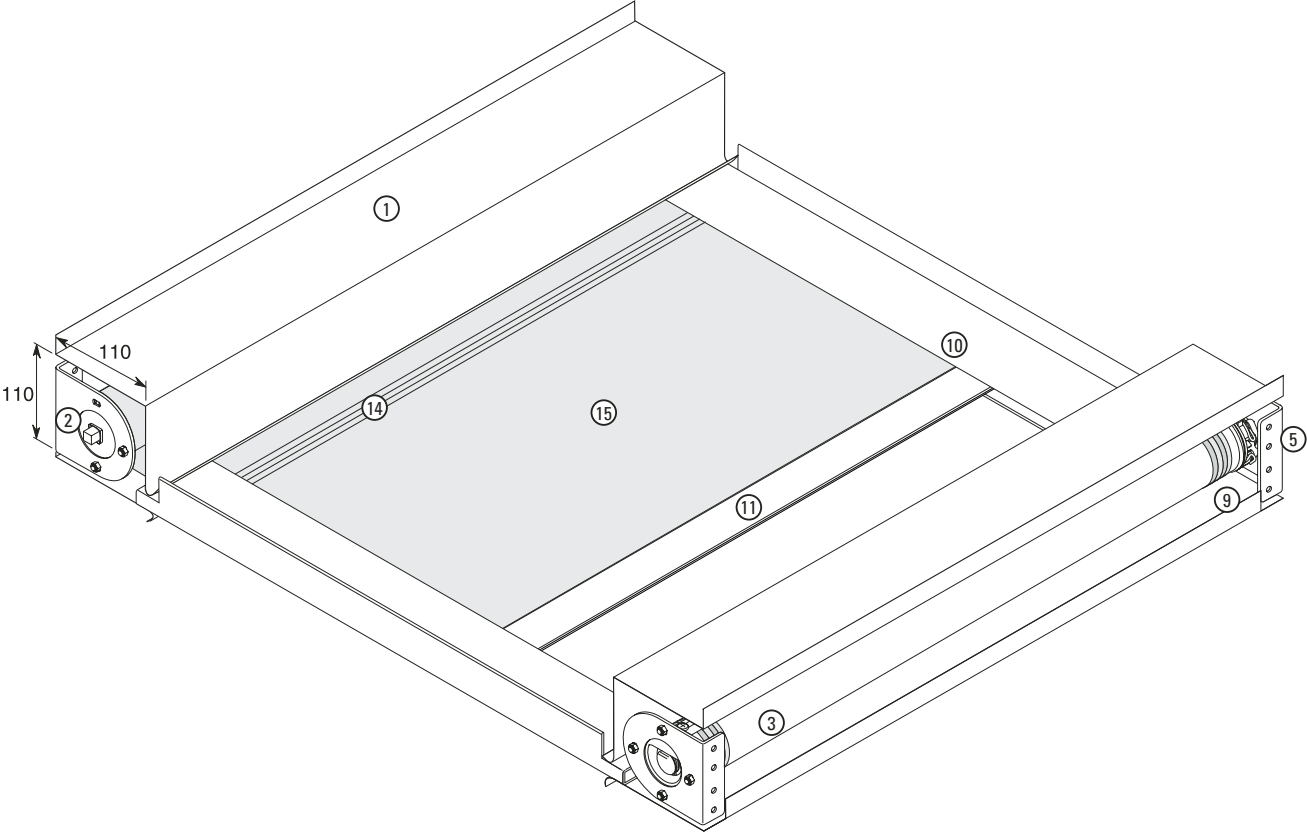

## Fixing

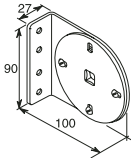

Idle end bearing bracket  
spring operated

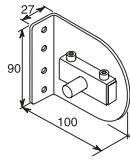

End bearing 120 pin

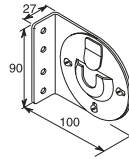

Idle end bearing bracket

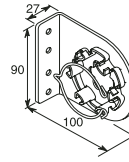

Motor bearing bracket

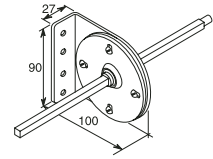

Intermediate bearing bracket  
for coupled blinds

Faber 1800 OL Blackout Blinds can be installed with different sizes of head box or without a blind box for concealed installations. The brackets are made from galvanised steel and the roller/draw tube end bearing assemblies are fitted directly to the brackets. Brackets with built-in bearings are also available for special installations. With coupled blinds particular care must be taken that the brackets are level and there are no major irregularities between the blinds

## Dimensions

	Rod control	Motor Control	Motor Control FTS
Min Width (mm)	700	700	700
Max Width (mm)	3500	3500	4500
Max Length (mm)	2500	2500	6000
Max Area, single	4 m <sup>2</sup>	8.75 m <sup>2</sup>	27 m <sup>2</sup>
Max Area, coupled	4 m <sup>2</sup>	50 m <sup>2</sup>	Not Available

## Other products

Alternative blackout roller blind systems are available for vertical applications. Faber 1800 is a similar system using many of the same components as the Faber 1800 OL suitable for large areas of glazing, and Faber 2000 is a system with a rounded cassette head box – see separate datasheets Faber 1800 and Faber 2000.

## Maintenance

The components used for Faber 1800 OL blinds are made from high quality, maintenance free materials. All plastic parts are UV resistant and self-lubricating. The head box, bottom bar and side channels can be cleaned with a moist sponge or cloth and a mild detergent.

### Warranty and guarantee

Faber offer a guarantee that its window blind products will be free from defects in materials and workmanship under normal and correct use for a period of 2 years from the date of purchase. This warranty is conditional on the product being installed correctly in accordance with the fixing instructions and applies to the original installation only, in the specific window for which it was intended. The warranty excludes any conditions or damages resulting from accidents, alterations, misuse, abuse or failure to follow the printed instructions with respect to measurement, installation, cleaning or maintenance of the product. The obligation of Faber and its licensed fabricators is limited to the repair or replacement of the blind or the components found to be defective, and excludes any freight charges or associated costs of removal and reinstallation.

### Disclaimer

With ongoing product development we reserve the right to make alterations to the product specification without prior notice.

The maintenance of the fabric will depend on the material composition and properties of the type selected. The fabrics can be dusted with a feather duster or a vacuum cleaner set on low suction power, and some fabrics can be gently wiped with a slightly moist sponge. For specific cleaning instructions please refer to the technical details of the relevant fabric.

## Testing

Faber blind systems are rigorously tested to guarantee trouble free function, performance and service durability. The design and manufacture of each system takes into consideration Health, Safety and Environmental issues in compliance with the relevant European legislation.

All Faber component parts and assembled blinds are manufactured and controlled during production in accordance with a quality system certified under EN ISO 9001: 2000 version.